

### Improve Operator Ergonomics



### Reduce Damage



### Increase Productivity



Put a Cascade Fork Positioner To Work For You.



# Ideal for the Majority of Applications

## *K-Series Hang-On & Integral Fork Positioners*

### **APPLICATIONS:**

Recommended for trucks in distribution, warehousing and manufacturing applications. These high-visibility Fork Positioners allow the operator to accurately position the forks from the driver's seat to better handle a variety of pallet configurations. Integral Fork Positioners available through various OEM programs, contact Cascade.

### **FEATURES:**

- Mounting Class 2, 3 or 4
- 2500-7500 kg capacities
- No-weld installation
- OEM load backrest compatibility
- 75, 100, 125, 150 or 175 mm wide fork carriers
- Zinc-plated corrosion resistant components
- Forks not included
- Maximum frame width:
  - 2500 / 3000 kg = 1300 mm
  - 4500 kg = 1400 mm
  - 5500 / 7000 / 7500 kg = 1550 mm

For forks longer than 1500 mm, load centres exceeding 750 mm, or to determine which Fork Positioner is best suited for your application, consult Cascade.



# Versatile - For More Demanding Applications

## *L-Series Hang-On Fork Positioners*

### **APPLICATIONS:**

Ideal for outdoor applications or in the most rugged and corrosive environments that require long forks or handling materials with extended load centres. Allows drivers to position forks accurately for a variety of load configurations, without ever leaving their seat.

### **FEATURES:**

- Mounting Class 2, 3 or 4
- 2500-7000 kg capacities
- Fork carriers with easy to service, durable, replaceable bearing segments ensure smooth travel and no wear on the fork hooks.
- Optional easy-to-install, full-width load backrest.
- Excellent operator visibility
- Standard flow divider circuit for equal fork movement.
- Unique design and construction allows fork carriers to extend beyond the frame width.
- Adjustable fork carriers accommodate various fork widths (forks not included).

For forks longer than 2500 mm, load centres exceeding 1250 mm or to determine which Fork Positioner is best suited for your application, consult Cascade.



## *G-Series Compact Fork Positioners*

### **APPLICATIONS:**

Designed as a compact unit with optimal visibility and excellent specifications it provides the optimal productivity improvement for your lift truck. Equipped with an external sideshift this Fork Positioner allows standard ISO Hook-type forks to be used. Recommended for use in distribution, warehousing and manufacturing.

### **FEATURES:**

- Quick no-weld installation
- 2500-5000 kg capacities
- OEM load backrest compatibility
- Accepts 80-150 mm wide forks
- Sideshifting or Non-Sideshifting





# Pin-Type Forks or Carriers for Heavy-Duty Applications

## PFS-A/PFS-F Hook-On Fork Positioners

### APPLICATIONS:

Recommended for a wide range of pallet handling applications in logistic operations, both indoors and outdoors, as well as in demanding manufacturing, car production and food processing plants.

### FEATURES:

- Mounting Class 2 or 3
- 2500-5000 kg capacities
- Sideshifting or non-sideshifting
- Designed to fit on standard ITA Class 2 or 3 trucks
- Accepts either ISO or pin-mounted forks
- Excellent visibility through the frame



## R-Series Fork Positioners

### APPLICATIONS:

Ideal for applications where heavy lifting is required. Recommended for metal, stone and automotive operations.

### FEATURES:

- Mounting Class 4
- 6000-11000 kg capacities
- Separate sideshift or non-sideshifting
- Designed to fit on standard ITA Class 4 trucks
- Accepts either ISO or pin-mounted forks



For forks longer than 3200 mm, load centers exceeding 1600 mm, or to determine which Fork Positioner is best suited for your application, consult Cascade.

## W/V-Series Fork Positioners

### APPLICATIONS:

Heavy duty fork positioners for a wide range of pallet and load handling applications, both indoors and outdoors.

### FEATURES:

- Mounting Class 2, 3 or 4
- 2000-16000 kg capacities
- Hook-on mounting for quick and easy installation or integral mast mounting for optimal truck capacity
- Integral hydraulic sideshift enables sideshift via fork positioning cylinders, providing optimum visibility
- Bearing-mounted pin-type forks with bottom heel rollers or bearing/roller-mounted ISO fork carriers.



# Wide Opening Applications

## G-Series Hang-On Fork Positioners

### APPLICATIONS:

For applications requiring a wide opening range to handle the load. Unlike conventional fork positioners, these forks extend beyond the frame width.

### FEATURES:

- Mounting Class 2, 3 or 4
- 1500-7000 kg capacities
- No-weld installation
- Bolt-on forks included
- Various frame widths available



## UPF/UPS-Series Fork Positioners

### APPLICATIONS:

Perfect for heavy duty loads that require a wide-opening range.

### FEATURES:

- Mounting Class 2, 3 or 4
- 1500-6500 kg capacities
- Telescopic frame enables the arms to extend outside the carriage
- ISO fork adaptors for use with standard ISO hook-type lift trucks/welded forks
- ISO hook-on mounting
- External sideshifter

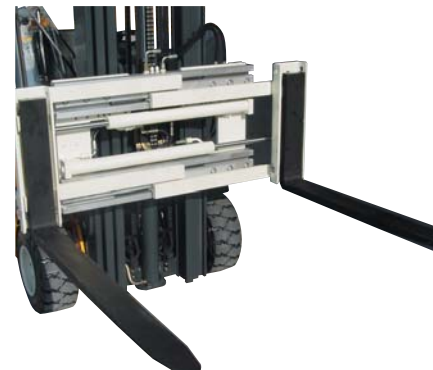

*Cascade Fork Positioners are used in a variety of industries, for any number of applications. The ability to position the forks from the driver's seat, rather than getting off the truck, saves time and reduces product and pallet damage.*

*Contact Cascade...  
Your Fork Positioner Consultant.*

# Whatever the application, we can handle it.



## DID YOU KNOW...

*You can convert your Sideshifter to a Fork Positioner?*

When you purchase a C-Series Integral or F-Series Hook-On Sideshifter from Cascade, not only are you getting the highest quality attachment available on the market today, but you are also getting the option to convert that same Sideshifter into a K-Series Fork Positioner for added functionality.

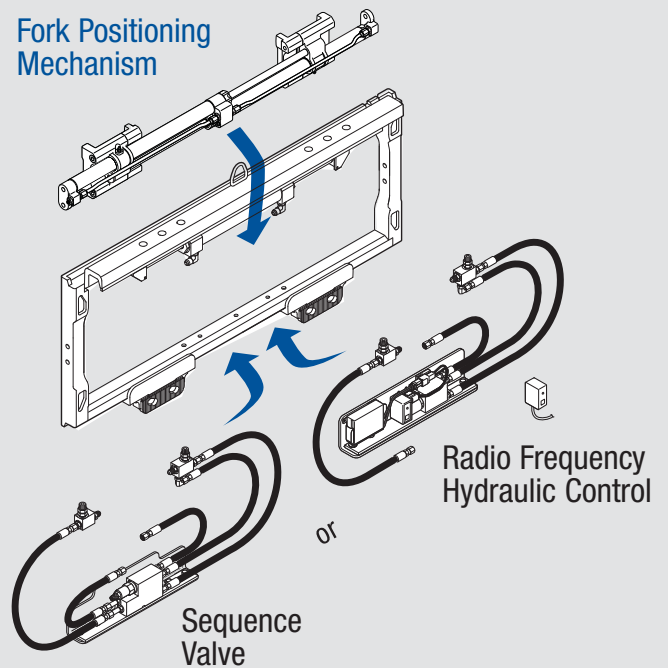

+



=



Cascade European Headquarters • Cascade Italia S.r.l. • Via Dell'Artigianato 1 • 37030 Vago di Lavagno (VR) • Italy • Tel. +39-045-8989111 • Fax +39-045-8989160  
Cascade Benelux/Parts Depot • Damsluisweg 56 • PO Box 3009 • 1300 EL Almere, The Netherlands • Tel +31 036 54 92 950 • Fax +31 (0) 36 54 92 974  
Cascade GmbH • Max-Planck-Straße 15b • 40699 Erkrath • Germany • Tel. +49 211 59 89 55 0 • Fax +49 211 59 89 55 11

Cascade is a registered trademark of Cascade Corporation.  
© Cascade Corporation 2014. All rights reserved.

**cascade**  
EUROPE

Form 6055404\_UK 04/14