



Rugged and reliable... time after time.



L-Series Fork Positioners

Your material handling advantage for demanding applications.

Designed for harsh environments and rigorous applications, the L-Series Fork Positioner is designed to accomplish even the most challenging tasks with ease. Great for applications that require longer forks or handling loads with extended load centres.

Available in Class 2, 3 or 4 with capacity ranges from 2500 kg to 7000 kg, this versatile Fork Positioner is a workhorse built to handle your toughest challenges.

Outperforms in the toughest applications.

SECURE

Optional bolt-on full-width load backrest

CONTROL

Standard flow divider circuit for equal fork movement

CONNECT

Several termination options to make installation quick and easy

SEE

Excellent operator visibility through and over the top of the frame

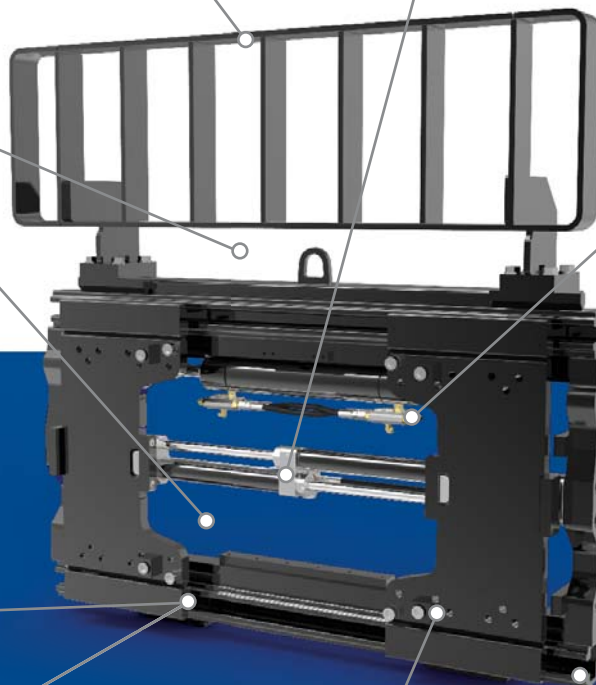

ENDURE

Long lasting replaceable bearing segments ensure smooth travel and no wear on the fork hooks



ADAPT

Adaptable fork carriers accommodate various fork widths and can be adjusted so the forks are full out or full in

EXTEND

Unique design and construction allows fork carriers to extend beyond the frame width

Whatever the application, we can handle it.



Quiet

With no metal-on-metal moving parts, the L-Series Fork Positioner is quiet during sideshifting and fork positioning. It doesn't just sound better, there's also no metal shavings, which eliminates problems due to contamination and corrosion.

Reliable

The bearings used in the L-Series Fork Positioner have been field tested and proven to be incredibly durable and long lasting. The fork carriers riding on these bearings eliminate potential wear on load bearing components.



Durability Comes Standard

The L-Series Fork Positioner comes standard with bronze lower sideshift hooks for added longevity and has many optional features:

- **Independent Fork Control** for the ultimate in fork manipulation.
- **Radio Frequency & Sequence Valve Hydraulic Controls** to make installation and operation quick and simple.
- **Anti-Drift Hydraulics** to eliminate any unwanted movement and ensure the forks are exactly where you want them.
- **Custom Load Backrests** can be made to meet the configuration your application requires.

